

INSTALLATION ADJUSTMENT SERVICE

HIGHLOW THERMOSTATIC WATER MIXING VALVE

MODEL XL-690, XL-690-LF

IMPORTANT! Provide valve serial number, (located on valve cover) when ordering parts!!

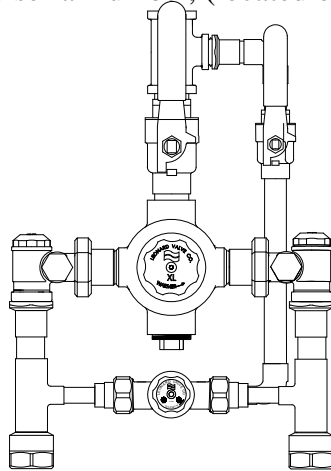

INSTALLATION



WARNING: This product can expose you to chemicals including lead, which is known to the State of California to cause cancer. For more information, go to www.P65Warnings.Ca.gov

1. Valve should be installed at a location where it can easily be cleaned, adjusted or repaired.
2. The inlets are clearly marked on the valve body. Do not connect the hot water to cold inlet, and vice versa. Doing so will cause the valve to operate improperly.
3. An external shutoff should be installed downstream of the mixing valve assembly outlet as an extra safety precaution.
4. Use solder, or thread sealant sparingly. Supply pipes should be flushed before the valve is connected. Flush outlet pipe and valve as soon as it is connected.

125 PSI (8.6 BAR) MAXIMUM OPERATING PRESSURE

CAUTION

All thermostatic water-mixing valves have limitations. They will not provide the desired accuracy outside of their flow capacity range. Consult the flow capacity chart on page 5.

Minimum flow must be no less than as shown.

REMEMBER! THIS IS A CONTROL SYSTEM WHICH MUST BE CLEANED AND MAINTAINED ON A REGULAR BASIS (SEE MAINTENANCE GUIDE AND RECORD MGR-1000).

INSTALLATION

REQUIRED METHODS OF PIPING XL SERIES

METHOD #1

Required when **TEMPERED WATER** is **NOT CIRCULATED**. Only the hot water supply to the mixing valve can be circulated with this piping arrangement.

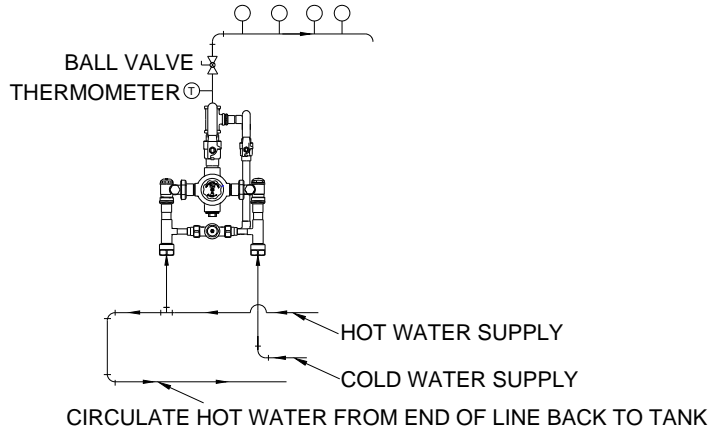

METHOD W

Required when **TEMPERED WATER IS CIRCULATED**.

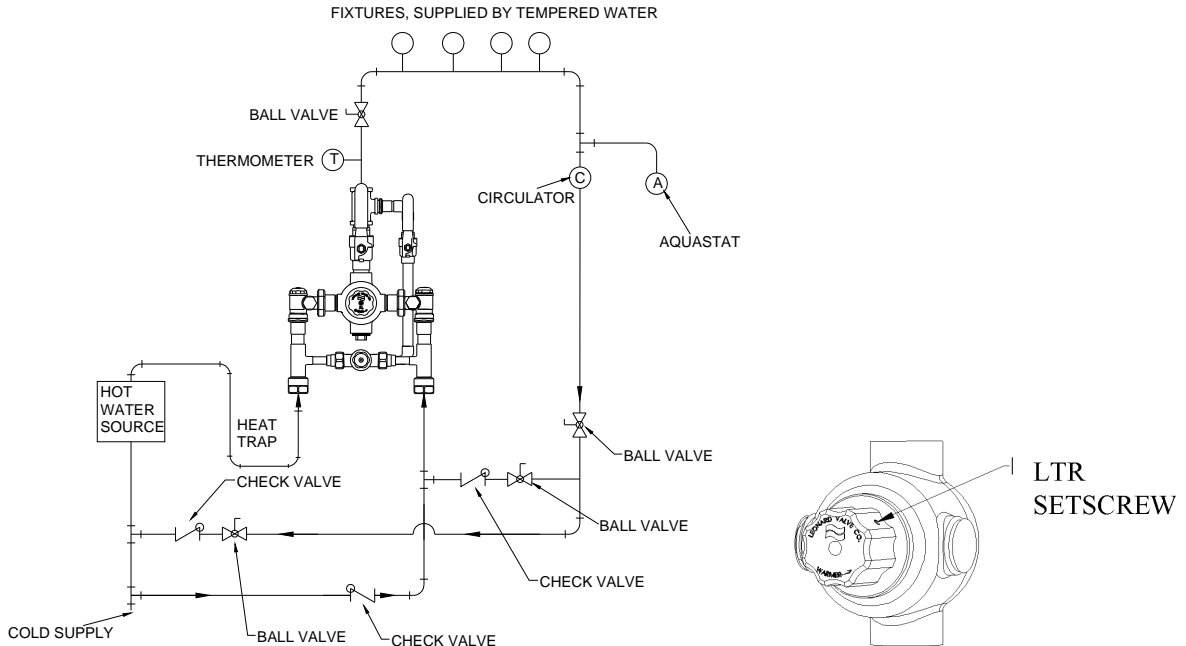

OPERATION

1. Verify that the temperature of the hot water source is properly set and maintained. Shutoff and isolate the circulator pump.
2. Loosen LTR set screw located on temperature adjustment knob with Allen wrench on both valves.
3. To set the small valve, turn off large valve using the ball valve on the outlet. Turn on enough fixtures to flow approximately 1.5 GPM, turn knob clockwise until it stops (full cold) then counterclockwise until it stops (full hot), three times to exercise the thermostatic element.
4. Set mixing valve to the desired temperature, (See warning tag for temperature set point). Tighten LTR set screw.
5. To set the large valve, turn off small valve using the ball valve on the 3/4" outlet. Turn on enough fixtures to flow approximately 5 GPM, turn knob clockwise until it stops (full cold) then counterclockwise until it stops (full hot), three times to exercise the thermostatic element.
6. Set mixing valve to the desired temperature, (See warning tag for temperature set point). Tighten LTR set screw.
7. Open ball valve on the 3/4" line on the outlet of the small valve and shut off all fixtures. Setup is complete.
8. Turn on circulator. With all fixtures still off, (no water flowing) observe the circulation temperature until it stabilizes.
9. If temperature rises, close balance valve until desired temperature is reached.

INSTALLATION CONTINUED

<p>WARNING</p> <p>WARNING! This Thermostatic Mixing Valve has an Locking Temperature Regulator (LTR) which must be checked. If the temperature is too high, the installer MUST RESET this adjustment immediately. Always check the temperature of the mixed water after installation. Excessively hot water is DANGEROUS AND MAY CAUSE SCALDING!</p>	<p>The LTR is factory set at approximately 120°F (49°C) with an incoming hot water supply temperature of 150°F (65°C) If the incoming hot water supply for your installation is higher than 150°F (65°C), the valve may deliver water in excess of 120°F (49)° and the LTR MUST BE RESET BY THE INSALLER.</p>
--	--

SERVICE

Leonard Type XL Thermostatic Water Mixing Valves are simple in design and may be easily cleaned, adjusted and repaired. If the installation is accessible, servicing may be completed without disconnecting the valve.

NOTE: Thermostatic Water Mixing Valves are REGULATING mechanisms, which must be regularly maintained to provide best performance. Frequency of cleaning depends on quality of local water conditions and usage. (See Maintenance Guide and Record MGR-1000).

TROUBLESHOOTING INSTRUCTIONS

ITEM:	PROBLEM:	RECOMMENDED REPAIR KITS (LARGE VALVE)	RECOMMENDED REPAIR KITS (SMALL VALVE)
PACKINGS & GASKETS	<ol style="list-style-type: none"> 1. Leak at stem. 2. Leak between valve cover and base. 	KIT 1/XL82	KIT 1/WX
SHUTTLE ASSEMBLY	<ol style="list-style-type: none"> 3. Valve delivers either all hot or all cold water, or will not mix consistently. 	KIT R/XL82	KIT R/269
CHECKSTOPS	<ol style="list-style-type: none"> 4. Hot water bypass into cold line. 5. Supplies cannot be shut off completely. 6. Leak at checkstop bonnet. 	KIT 2/690	SEE PAGE 5

REMEMBER! THIS IS A CONTROL DEVICE WHICH MUST BE CLEANED AND MAINTAINED ON A REGULAR BASIS. (SEE MAINTENANCE GUIDE AND RECORD, MGR-1000).

LARGE VALVE PARTS LIST

KIT #	TYPE KIT	INCLUDES
KIT R/XL82	REPAIR KIT	1-7
KIT 1/XL82	O-RING	2,3,6,7
KIT 2/690	CHECK	11-16

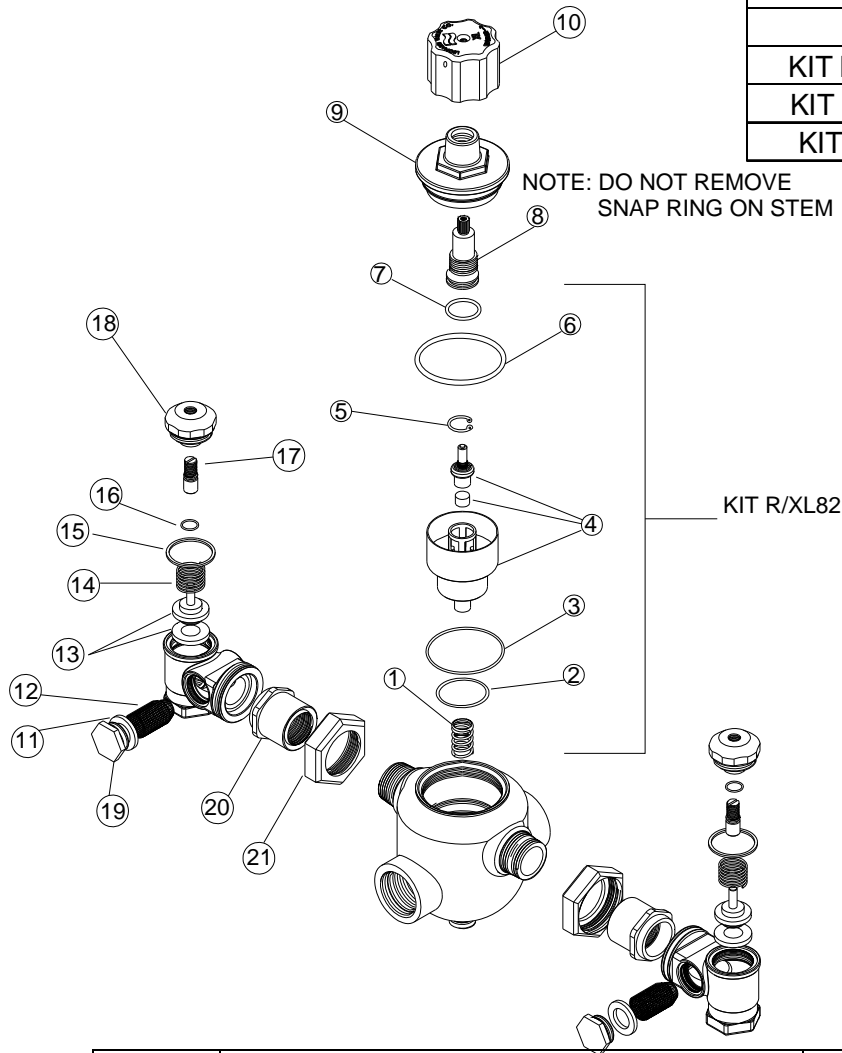

ITEM #	DESCRIPTION	QTY.	PART # / KIT #
			XL-82
1	SPRING, RETURN	1	KIT R/XL82
2	O'RING, LOWER SHUTTLE	1	KIT 1/XL82, KIT R/XL82
3	O'RING, UPPER SHUTTLE	1	KIT 1/XL82, KIT R/XL82
4	SHUTTLE ASSEMBLY	1	KIT R/XL82
5	RETAINING RING, COVER	1	7611, KIT R/XL82
6	O'RING, COVER	1	KIT 1/XL82, KIT R/XL82
7	O'RING, STEM	1	KIT 1/XL82, KIT R/XL82
8	STEM ASSEMBLY (DO NOT REMOVE SNAP RING)	1	761900
9	COVER	1	7604
10	KNOB ASSEMBLY	1	764000
11	PACKING, STRAINER CAP	2	014, KIT 2/690
12	SCREEN	2	013, KIT 2/690
13	LOWER STEM & PACKING	2	03, KIT 2/690
14	SPRING,CHECK	2	KIT 2/690
15	PACKING, BONNET	2	05, KIT 2/690
16	O'RING, UPPER STEM	2	MU-5A, KIT 2/690
17	STEM, UPPER CHECK	2	MU-4A
18	BONNET	2	2
19	STRAINER CAP	2	6
20	SWIVEL	2	04/50
21	SWIVEL NUT	2	09/50

SMALL VALVE PARTS LIST

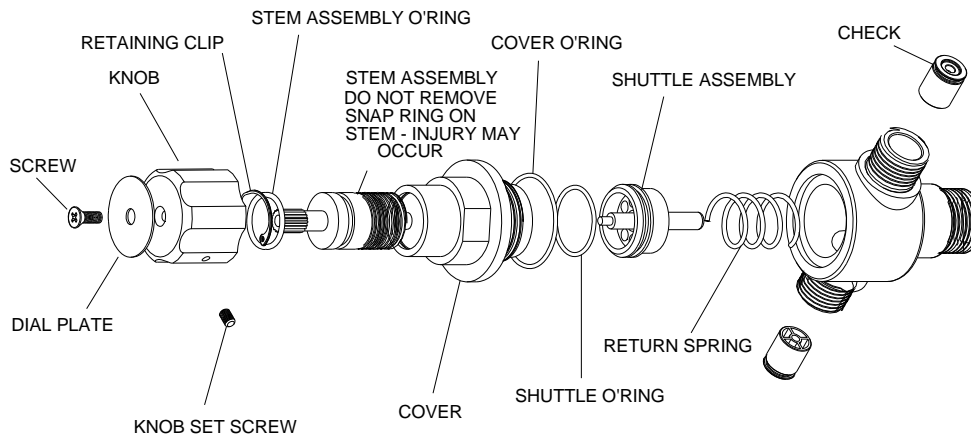

MODEL 269-USW (unions part of valve body)	MODEL 269-LF
<u>1/WX Gasket Kit</u>	<u>1/WX Gasket Kit</u>
Shuttle o-ring	Shuttle o-ring
Stem assembly o-ring	Stem assembly o-ring
Cover o-ring	Cover o-ring
<u>R/269 Rebuild Kit</u>	<u>R/269 Rebuild Kit</u>
Return spring	Return spring
Shuttle assembly	Shuttle assembly
Shuttle o-ring	Shuttle o-ring
Stem assembly o-ring	Stem assembly o-ring
Cover o-ring	Cover o-ring
<u>4/220USW Check valve Kit</u>	<u>4/220 Check valve Kit</u>
2 Check valves	2 Check valves
3 Union gaskets	3 Check clips

DISMANTLING & CLEANING

1. Shut off hot and cold water to the valve as well as the valve outlet port.
2. Loosen lock screw on side of knob with 5/64" allen wrench.
3. Remove the knob screw on top of knob.
4. Remove temperature adjustment knob.
5. Remove valve cover, which includes the stem assembly.
6. The shuttle assembly can now be removed, cleaned and inspected. Be sure to check the condition of the shuttle o-ring and replace if necessary.
7. Lubricate the shuttle o-ring before installing the shuttle assembly.
8. Install the cover assembly including o-ring back onto valve and tighten.
9. Replace knob and knob screw.
10. **Valve temperature must be reset after any repairs or cleaning!! See Page 2. Temperature Adjustment**

TROUBLESHOOTING

1. Leaking water under knob, order gasket kit, replace stem assembly o-ring. Remove knob screw and knob, remove retaining clip, thread out the stem assembly and replace o-ring. Lubricate o-ring, thread stem into cover, replace retaining ring, knob and screw. **Valve temperature must be reset after any repairs or cleaning!! See page 2.**
2. Leaking water between cover and body, order gasket kit, replace cover o-ring. Remove knob screw and knob and remove valve cover and replace o-ring. Replace valve cover, knob and knob screw. **Valve temperature must be reset after any repairs or cleaning!! See page 2.**
3. Hot water bypass into cold line, order checkstop kit and replace checks within inlets of valve.
4. Valve not controlling temperature even after cleaning, order complete rebuild kit. Remove knob screw and knob and remove valve cover. Replace shuttle assembly and return spring being sure to lubricate shuttle o-ring. Replace valve cover, knob and knob screw. **Valve temperature must be reset after any repairs or cleaning!! See page 2.**

FLOW CAPACITIES

VALVE	PRESSURE DROP													
	MIN. FLOW	5	10	15	20	25	30	35	40	45	50	55	60	PSI
		0.3	0.7	1	1.4	1.7	2.1	2.4	2.8	3.1	3.4	3.8	4.1	BAR
XL-690	1	5	10	20	35	39	41	48	55	59	62	64	65	GPM
	3.8	19	38	76	132	148	155	182	208	223	235	242	246	l/min

NOTE: Flowrates will vary depending on existing field conditions. Leonard Valve Company always recommends using CASPAK® sizing software for proper valve sizing and model number applications.

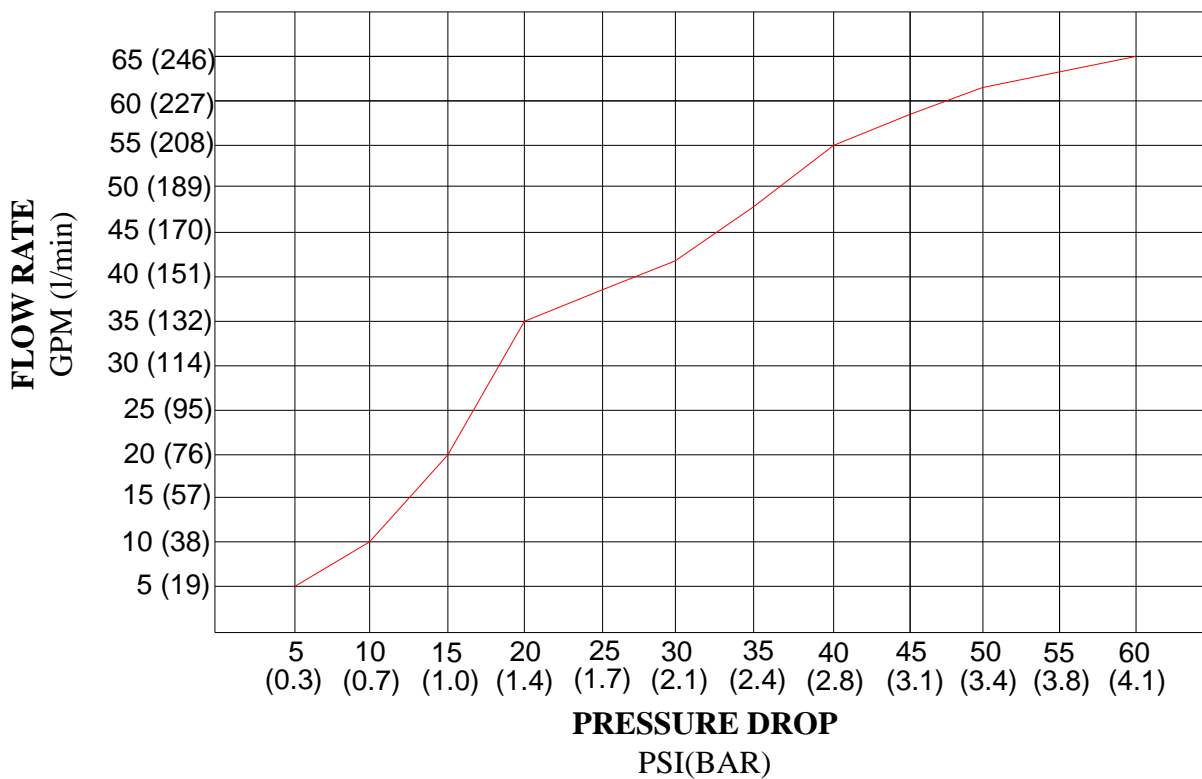

LIMITED WARRANTY

Leonard Valve Company warrants the original purchaser that products manufactured by them (not by others) will be free from defects in materials and workmanship under normal conditions of use, when properly installed and maintained in accordance with Leonard Valve Company's instructions, for a period of one year from date of shipment. During this period the Leonard Valve Company will at its option repair or replace any product, or part thereof, which shall be returned, freight prepaid, to the Leonard factory and determined by Leonard to be defective in materials or workmanship. There are no warranties, express or implied, which extend beyond the description contained herein. There are no implied warranties of merchantability or of fitness for a particular purpose. In no event will Leonard be liable for labor or incidental or consequential damages. Any alteration or improper installation or use of the product will void this limited warranty.